

TEMPERATUTE CONTROLLER

USER'S MANUAL (KN 804)

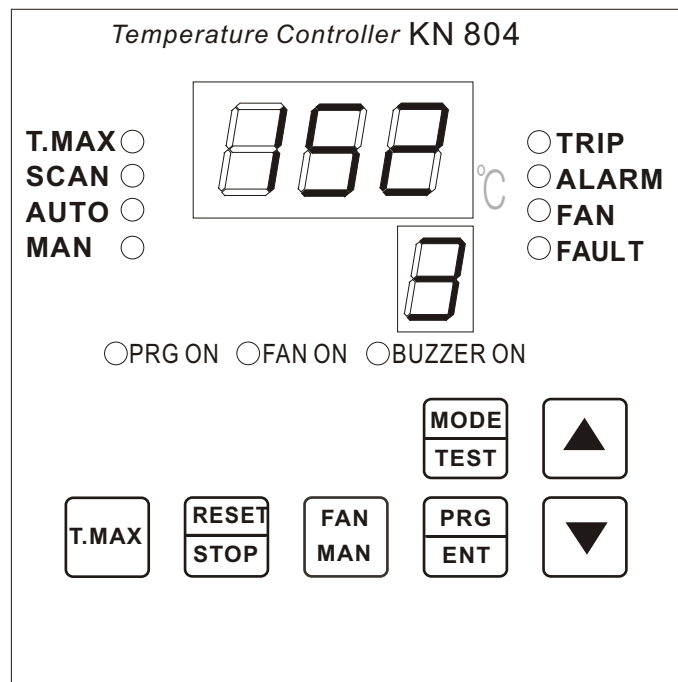

목 차 (CONTENTS)

| | |
|--|----|
| ● 안전을 위한 주의 사항(Caution for Safety) ----- | 2 |
| ● KN804 온도컨트롤러(TEMPERATURE CONTROLLER)----- | 6 |
| 1. 사양(Specifications)----- | 6 |
| 2. 외형도 및 판넬가동치수도(External Dimension and Panel Cutting Size)- | 7 |
| 3. 단자대 및 센서(Connection Diagram & Sensor)----- | 8 |
| 4. 특징(Features)----- | 9 |
| 5. 출력동작도(Output Operating Diagram)----- | 9 |
| 6. 각부 명칭(Name of Each Part)----- | 11 |
| 7. 동작 및 설정(Operation and Setting)----- | 11 |
| 8. 외부결선도(Example of Wring)----- | 15 |

안전을 위한 주의사항

- 안전을 위한 주의사항은 제품을 안전하고 올바르게 사용하여 사용자의 안전과 사고나 위험을 미리 막기 위한 내용으로 잘 읽고 반드시 지켜주십시오 .
- 주의사항은 경고 와 주의 의 두가지로 구분되며 그 의미는 다음과 같습니다.



경고

지시사항을 위반할 시 심각한 상해나 사망이 발생할 가능성이 있습니다.



주의

지시사항을 위반할시 상해나 제품의 손상 ,물질적인 손해의 가능성이 있습니다.



경고

1. 전원

- 1) 기기의 보호와 고장방지를 위해 정격 전원전압 이내에서 사용하십시오.
- 2) 기기의 설치 시 감전방지와 기기 손상을 방지하기 위해 배선의 결선이 완료된 이후에 결선을 확인하고 전원을 투입하십시오.

2. 동작상의 주의

- 1) 본 기기의 이상이 중대한 사고에 연관되는 경우엔는 출력부분에 보호장치를 추가 설치하는 것을 권장합니다.
- 2) 가스 중에서 사용을 금합니다. (방폭 구조가 아닙니다.)
- 3) 화학물질이 있는곳에서 사용하지 마십시오. 전기 누전 및 감전의 위험이 있습니다.
- 4) 통전중에 단자를 만지거나 풀지마십시오.
감전이나 오작동의 원인이 됩니다.
- 5) 근처에 물이있거나 몸이젖어있을때 제품을 만지지마십시오.
감전의 위험이 있습니다.
- 6) 어린이가 만질수있는 장소에 설치하지마십시오.

3.결선및 보수상의 주의

- 1) 본기기의 결선은 사용설명서나 부착된 단자설명서 같이 해당번호에 정확하게 결선하십시오. (단자 볼트는 단단히 잠그십시오.)
오결선 시 기기 파손 및 오동작 및 화재의 원인이 됩니다.
- 2) 보수시 필히 외부전원 스위치를 OFF 하고 출력부의 연결 외부 회로 전원을 차단후 보수,탈착하여 주십시오. 감전 고장의 원인이 됩니다.
- 3) 본 기기를 분해하거나 개조 수리는 절대하지마십시오.
감전 화재및 제품손상 ,오작동 고장의 원인이 됩니다.
- 4) SENSOR 를 교환할시에는 전원을 필히끄고 교환하십시오.
감전 화재의 제품의손상 오작동 고장의 원인이 됩니다.
- 5) 본 기기의 부품은 수명이있으며 경년변화 부품을 포함하고 있습니다.
구입일로 부터 1년동안 보증기간 입니다.
단, 고객의 과실 및 천재지변의에 의한 고장은 제외 됩니다.



주의

1. 취부 및 결선상의 주의

- 1) 취부 시 기기의 아래위 고정물 (출고 시 포함)로 단단하게 고정 하십시오
- 2) 전원에 유도 노이즈 등이 심한 경우 절연트랜스 및 노이즈 제거회로를 사용할 것을 권장합니다.
- 3) 물이 들어갔을 때는 필히 점검을 받으십시오.
감전과 화재의 원인이 됩니다.
- 4) 리드선은 저항이 작고 난연성이 있는 것을 사용하십시오.
- 5) 출력과 입력 신호선은 필히 분리하여 사용하십시오.

2. 취급상의 주의

- 1) 출력 Relay 를 정격에 여유 없이 부하를 접속하여 빈번하게 동작할 시에는 Relay 수명이 정격보다 짧아지므로 외부에 릴레이 를 추가하여 사용하십시오
Relay 전기적 수명-----약 10만회 (정격부하시)
- 2) 각 설정을 정확하게 설정하시고 운전 전에 입력과 출력 이상 유무를 확인 하십시오
- 3) SENSOR 가 단선 또는 SHORT 일 때는 "FuL" 표시 합니다.
이때 SENSOR를 교환 시에는 필히 전원을 OFF하십시오
고장 및 오동작의 원인이 됩니다.
- 4) 제품을 떨어뜨리거나 충격을 주지 마십시오 외관이 손상 됩니다.
- 5) 유기 용제로 제품을 닦지 마십시오 외관이 손상 됩니다
- 6) 다음과 같은 여건에서의 사용을 피하십시오.
: 주의 온습도가 사용조건의 온습도 범위를 초과하는곳
: 가연성 가스나 부식성 가스에 노출 되는곳
: 기름 물 수증기 철분 염분이 많은곳
: 방수 구조가 아니므로 옥외나 물 비등에 노출되는곳
: 직사광선에 바로 노출되는곳
: 온습도 변화가 심하여 결로 현상이 발생하는곳.

Caution for Safety

- Caution for safety, aims at securing safety of user and preventing accident or danger in advance by using it safely, so read and follow it well.
- Caution matters are divided into 'warning' and 'caution' whose meanings are as follows



WARNING

Violating instruction may cause serious damage or death



CAUTION

Violating instruction may cause injury product damage or material loss.



WARNING

1. power

- 1) use it within rated voltage in order to protect equipment and prevent and prevent trouble.
- 2) In order to prevent electric shock and equipment damage when installing equipment check wiring after finishing wiring and then input power.
- 3) use standard wiring and terminal for connecting power. this can cause electric shock and fire.

2. caution for operation

- 1) If abnormality of this equipment is related to serious accident, it is recommended to install protection device in addition.
- 2) Do not use this equipment in the gas (This is not explosion-proof structure). If this equipment is exposed to gas do not operate power switch and so on but operate and it when it is safe after venting the space.
- 3) Do not use in the place with chemical materials, There is danger of electric leakage and electric shock.
- 4) Do not touch or loosen terminal when there is applied It can cause electric shock or mal-operation.
- 5) Do not touch the product when there is water around or when body is wet. There is danger of electric shock.
- 6) Do not install the equipment in the place where children can touch the equipment.

3. Caution for wiring and maintenance

- 1) Perform wiring for this equipment exactly into relevant number as show in the instruction manual or terminal instruction. (Tighten terminal bolt firmly) mal-wiring can cause equipment damage, mal-operation of fire.
- 2) Perform repair or assembling after turning off external power switch and interrupting external circuit power. It can cause electric shock or trouble.
- 3) Never disassemble reform or repair equipment It cause electric shock fire product damage mal-operation or trouble.

- 4) Replace sensor after turning off power by all means. It can cause electric shock.
Fire product damage mal-operation or trouble.
- 5) The components of this equipment have life period and include year -passing components There is 1 year of guarantee period from purchasing date.
However. Trouble due to customer mistake and natural disaster is excluded.



CAUTION

1. Caution for attachment and wiring

- 1) Fix the equipment firmly with the fixing device (included during shipment below and above the equipment when attaching equipment.
- 2) If there is severe induction noise in the power, it is recommended to use insulation transformer and noise removal circuit.
- 3) Twisted wiring of power line is effective for noise
- 4) If water enters receive checking by all means.
- 5) Use lead wire which has low resistance is non-combustible.
- 6) Use output and input signal lines by separation them by all means. Use shield wire for input signal wire and be away from load or high voltage.
- 7) Use sensor of non-grounding type.

2. Caution for handling

- 1) when operation output relay frequently by connecting load without allowance in rating, relay life can be shorter rating so use it by adding relay to outside. *Electric life of relay --About 100,000 times (under rated load)
- 2) Make each setting exactly and check abnormality in input and output,
- 3) If sensor is single or short it is displayed "---".
turn off voltage by all means when replacing sensor at this time .
It can cause trouble and mal-operation
- 4) Do not drop this product nor give shock this product. It can cause trouble or mal-operation
- 5) Do not wipe the product with organic solvent It can cause damage in appearance .
- 6) Avoid use in the following condition.
 - : In the place where surrounding temperature and humidity exceed the temperature and humidity scope in usage condition.
 - : In the place exposed to combustible gas or corrosive gas.
 - : In the place where there is much oil water steam iron or salt.
 - : In the place which is not waterproof structure exposed to outside water or rain.
 - : In the place directly exposed to direct sunshine.
 - : In the place where freezing phenomenon takes due to severe change of temperature and humidity.

KN804 DIGITAL TEMPERATURE CONTROLLER

- FREE VOLTAGE
(AC100~240V 50~60Hz,
DC 100~300V USED)
- SIZE 100(W)X100(H)X132(D)mm
- 4 SENSOR INPUT(Pt100Ω)
- PROGRAM TYPE FUNCTION
(SETTING VALUE)
- TEMP.MAX STORAGE FUNCTION
- DATA STORAGE FUNCTION
- FAN AUTO/MANUAL FUNCTION

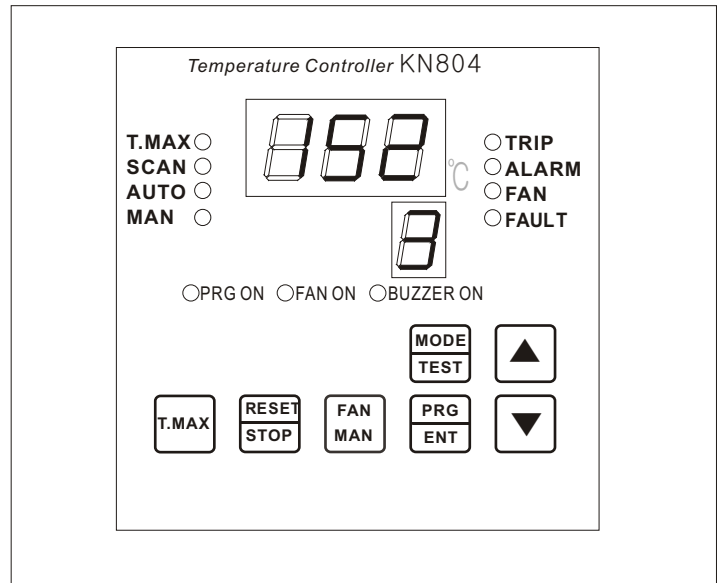

1. 사양 (Speccification)

| | |
|-------------------------------|---|
| DIMENSION | 100(W)X100(H)X132(D)mm |
| INPUT MEASURERING CYCLE | 100m SEC |
| ACCURACY | +/-0.5 °C (Full Scale) |
| INPUT | 4 INPUT Pt100Ω-3WIRE(DIN IEC 751) |
| AMBIENT TEMPERATURE & HUIDTIY | OPERATION -0 TO 55 °C /10 TO 90% RH) |
| MEASURING RANGE | -50~250 °C |
| TEMPERATURE INDICATION | 1 °C |
| OUTPUT CONTACTS CAPACITY | TRIP,ALARM AC 250V 5A(Resistance Load) FAN AC 250V 10A(Resistance Load) CONTACT DC 30V 10A(Resistance Load) |
| DATA STORAGE | 10 YEARS |
| POWER SUPPLY | FREE VOLTAGE AC 100V TO 240V 50~60Hz,DC 100~300V |
| POWER CONSUMPTION | 7 VA |
| DIELECTRIC STRENGTH | AC 2000V FOR 1MIN |
| INSULATION RESISTANCE | DC 500V 100M ohm MINIMUM |
| WEIGHT | 750g |

2. 외형도 및 판넬 가공치수도 (External Dimension and Panel Cutting Size)

◎ 외형도(External Dimension)

단위 : mm

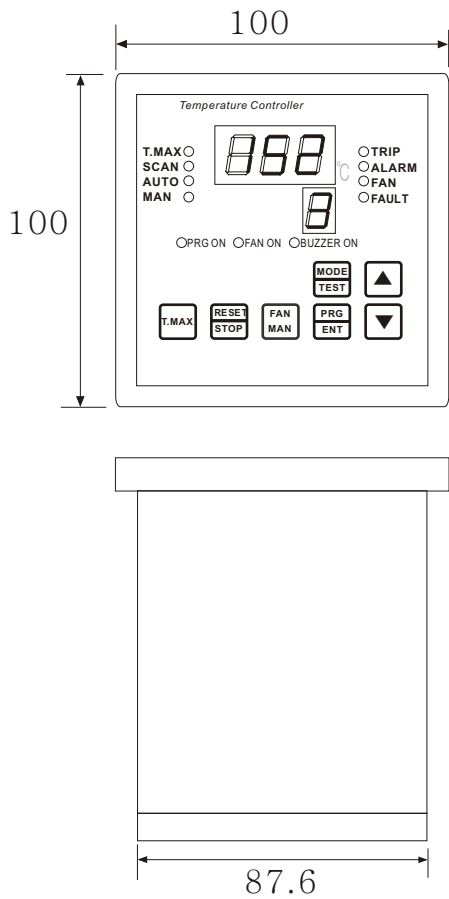

◎ 판넬가공치수도(Panell Cutting Size)

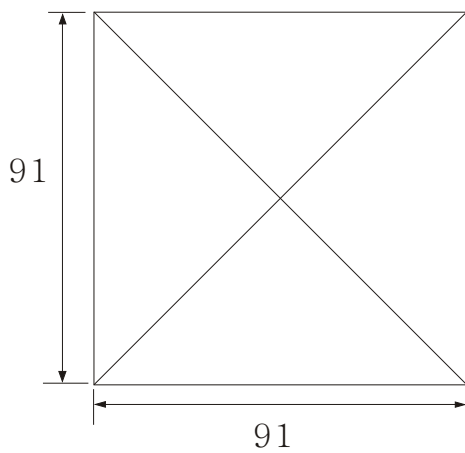

4. 특징

- ⊙ 전원 입력이 FREE VOLTAGE (AC 90~260V, DC 100~300V) 로 외부전원의 변화와 SURGE 등의 악조건에서도 안정적으로 작동합니다.
- ⊙ 3입력으로 변압기 온도를 표시하고 운전 중 온도에 따라 경보출력 (ALARM , TRLP) FAN 을 제어합니다.
- ⊙ 각 설정온도를 PRG KEY 의 의해 PROGRAM 식으로 설정 할수 있습니다.
TEMP .MAX기능 -현재까지의 동작중 변압기의최대온도를 저장 확인이 가능합니다.
- ⊙ DATA 저장 기능이 있어 T, MAX 값 각 제어온도 설정치를 기억합니다.
(반영구적)
- ⊙ T MAX, 치는 동작 중 RESET 을 시키지않는 한 전원 OFF후에도 저장됩니다.
- ⊙ 각 설정치도 동작 중 설치를 변경하지않는 한 전원 OFF후에도 저장됩니다.
- ⊙ FAN OUP기능 -FAN ON FAN OFF 설정치와 측정온도를 비교하여 외부 FAN 을 CONTROL 합니다.

5. 출력동작도

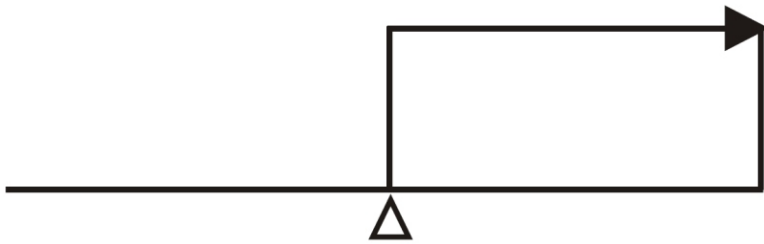
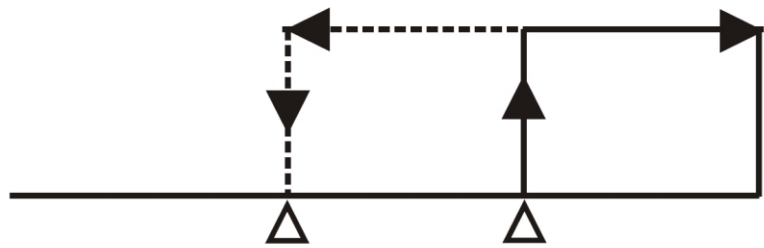
| OUTPUT | SPECIFICATIONS(△:setting temp) |
|-------------|--|
| ALARM, TRIP |  |
| FAN OUT |  |

4.Features

- ⊙ Power input is free voltage (AC 90~260V,DC 100~300V) and it is stably operated even at bad condition such as outside power change, surge etc
- ⊙ Temperature of transformer is measured and displayed and alarm output (alarm trip) and fan is controlled according to temperature.
- ⊙ It is possible to set each setting temperature in program type according to program key
- ⊙ Temp max function –It is possible to check the highest temperature of transformer during operation up to now.
- ⊙ Data storage function memorizes T .MAX value and each control temperature setting values.(Semi-eternal) T.MAX value is stored even after turning power it is reset during operation. Each setting value is also stored after turning off power unless setting value is changed during operation.
- ⊙ Fan out function –It is possible to control outside fan by comparing fan on and fan off setting values and measured temperature.

5.Output Operating Diagram

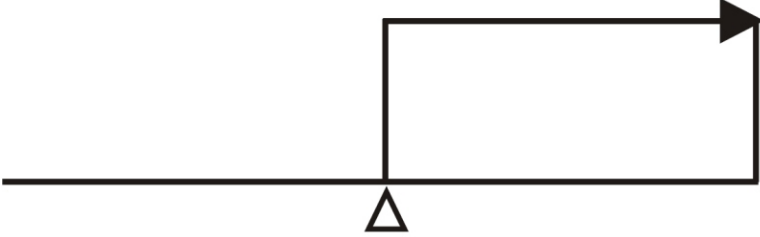
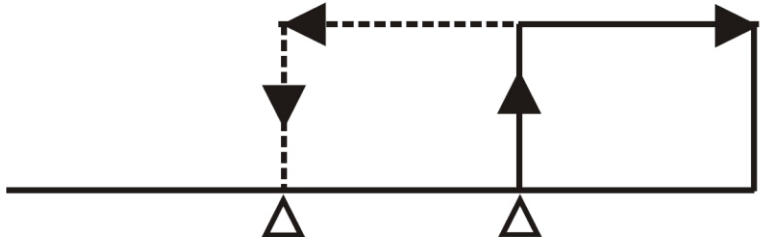
| OUTPUT | SPECIFICATIONS(Δ :setting temp) |
|------------|--|
| ALARM,TRIP |  |
| FAN OUT |  |

6. 각부의 명칭

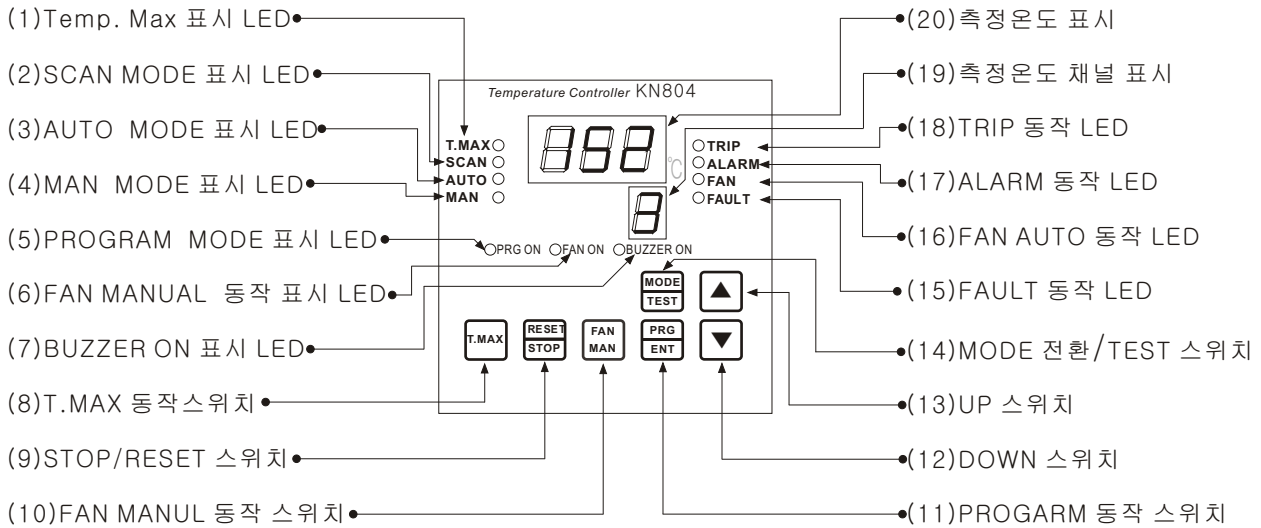

7. 동작및설정

| | |
|-----------|--|
| FUNCTIONS | <p>(1)T.MAX: 측정온도중가장높은온도값을 저장함</p> <p>(2)SCAN : 각채널을 일정시간 주기로 표시함</p> <p>(3)AUTO : 각채널 중 가장높은 온도 채널을 표시함</p> <p>(3)MAN : 각채널을 수동으로 상하키로 선택한 채널을 보여줌</p> <p>(16)FAN : FAN ON/OFF 자동으로 동작함을 표시함</p> <p>(17)ALARM: ALARM ON/OFF 자동으로 보여줌</p> <p>(18)TRIP : TRIP ON/OFF 자동으로 보여줌</p> |
| 조작 KEY | <p>(8)T.MAX: T.MAX값 동작스위치</p> <p>(9)STOP/RESET: STOP은 BUZZER 동작 정지 스위치 RESET은 T.MAX MODE에서 기존 저장값을 삭제 함(3초간누름)</p> <p>(10)FAN MAN: FAN 동작을 수동으로 ON/OFF 스위치</p> <p>(11)PRG/ENT: PROGRAM MODE 전환 스위치(3초간 누름) 설정값 변경 및 저장 함</p> <p>(12)DOWN: 측정채널 낮은채널로 이동 PROGRAM SETTING 값 내림.</p> <p>(13)UP : 측정채널 높은채널로 이동 PROGRAM SETTING 값 올림.</p> <p>(14)MODE/TEST: DISPLAY MODE(SCAN, AUTO, MAN) 전환키 TEST MODE 키 (3초간 누름)</p> |

6. Name of Each Part

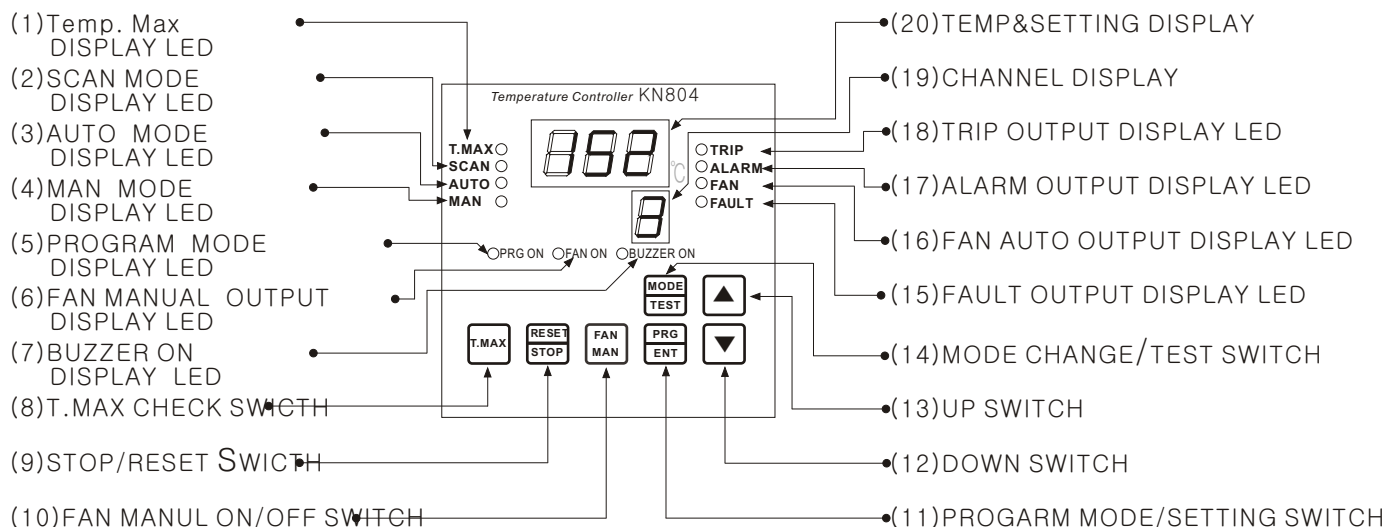

7. Operating and Setting

| | |
|----------------|--|
| FUNCTIONS | <p>(1) T.MAX: Monitoring unit shows the highest temperature recorded by the sensor and the last reset</p> <p>(2) SCAN: Control device displays in scansion all activated channels (each 2 seconds)</p> <p>(3) AUTO: Control device automatically displays the highest temperature channel</p> <p>(3) MAN: Channel temperature manual reading through cursor keys</p> <p>(16) FAN: FAN is automatically controlled by fan on and fan off setting value</p> <p>(17) ALARM: When the measurement temperature is over ALARM setting value, ALARM ON</p> <p>(18) TRIP: When the measurement temperature is over TRIP setting value, TRIP ON</p> |
| OPERATION KEYS | <p>(8) T.MAX: T.MAX value check key (SCAN, AUTO, MAN mode only)</p> <p>(9) STOP/RESET: STOP → (When the buzzer on) The "STOP/RESET" key is pressed the buzzer will stop. RESET (In T.MAX MODE) → The current T.MAX value delete and record again ("STOP/RESET" key 3 seconds pressing)</p> <p>(10) FAN MAN: FAN operation the button which the ON/OFF operation with a manual operation.</p> <p>(11) PRG/ENT: PROGRAM MODE ("PRG/ENT" key 3 seconds pressing) Program setting function key</p> <p>(12) DOWN: When Program setting value change DOWN.</p> <p>(13) UP: When Program setting value change UP.</p> <p>(14) MODE/TEST: DISPLAY MODE (SCAN, AUTO, MAN) change key TEST MODE key ("MODE/TEST" key 3 seconds pressing)</p> |

설정 메뉴얼

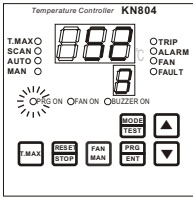

전원이 투입되면
측정모드로 온도 값이 표시 됩니다.

PRG
ENT 키를 3초간 누릅니다.
☀️PRG ON PRG ON 램프에 불이 들어옵니다.



"FAN ON" 설정 표시입니다.



▲▼ "FAN ON" 설정 값을 변경합니다.



설정 한 값을 저장합니다.

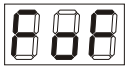

"FAN OFF" 설정 표시입니다.



▲▼ "FAN OFF" 설정 값을 변경합니다.



설정 한 값을 저장합니다.



"ALARM ON" 설정 표시입니다.



▲▼ "ALARM ON" 설정 값을 변경합니다.



설정 한 값을 저장합니다.

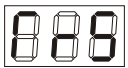

"TRIP ON" 설정 표시입니다.



▲▼ "TRIP ON" 설정 값을 변경합니다.



설정 한 값을 저장합니다.

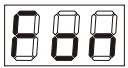

처음 화면으로 돌아옵니다.



* 프로그램 안에서 어디서든 **PRG**
ENT 키를 3초간 누르거나 키 동작이
30초간 없으면 측정모드로 전환 됩니다.



* 측정모드

● PRG ON PRG ON 램프 불이 꺼집니다.

Setting manual

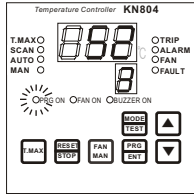

After power supply
The display shows the measurement temperature

Pressing key 3 seconds

PRG ON PRG ON led turns on

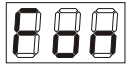

"FAN ON" Setting display



"FAN ON" Setting value changes



Save the changed setting value

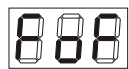

"FAN OFF" Setting display

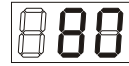

"FAN OFF" Setting value changes



Save the changed setting value



"ALARM ON" Setting display



"ALARM ON" Setting value changes



Save the changed setting value

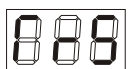

"TRIP ON" Setting display



"TRIP ON" Setting value changes



Save the changed setting value

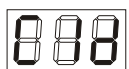

"COM ID" Communication ID setting display



*Use the products only applies to communications



"COM ID" Setting ID value changes



Save the changed setting value

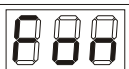

Return to first display



*Anywhere in the program by pressing key 3 seconds
or key operation is not longer than 30 seconds
in the measurement mode is changed.



*Measurement mode

PRG ON PRG ON led turns off

8.FAN 외부결선도(Example of Wiring)

◎ 단상 FAN 외부 결선도(In case of Phase)

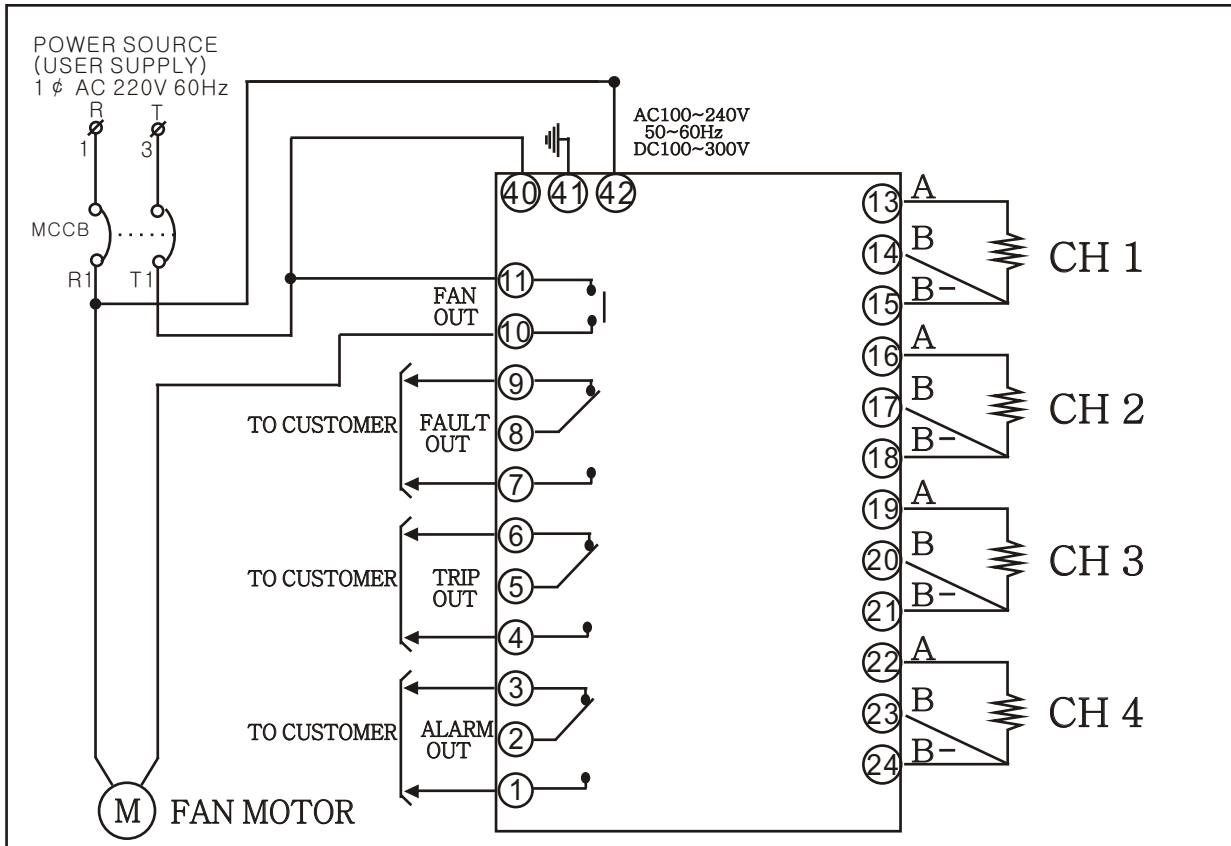

◎ 삼상 FAN 외부 결선도(In case of Three Phase)

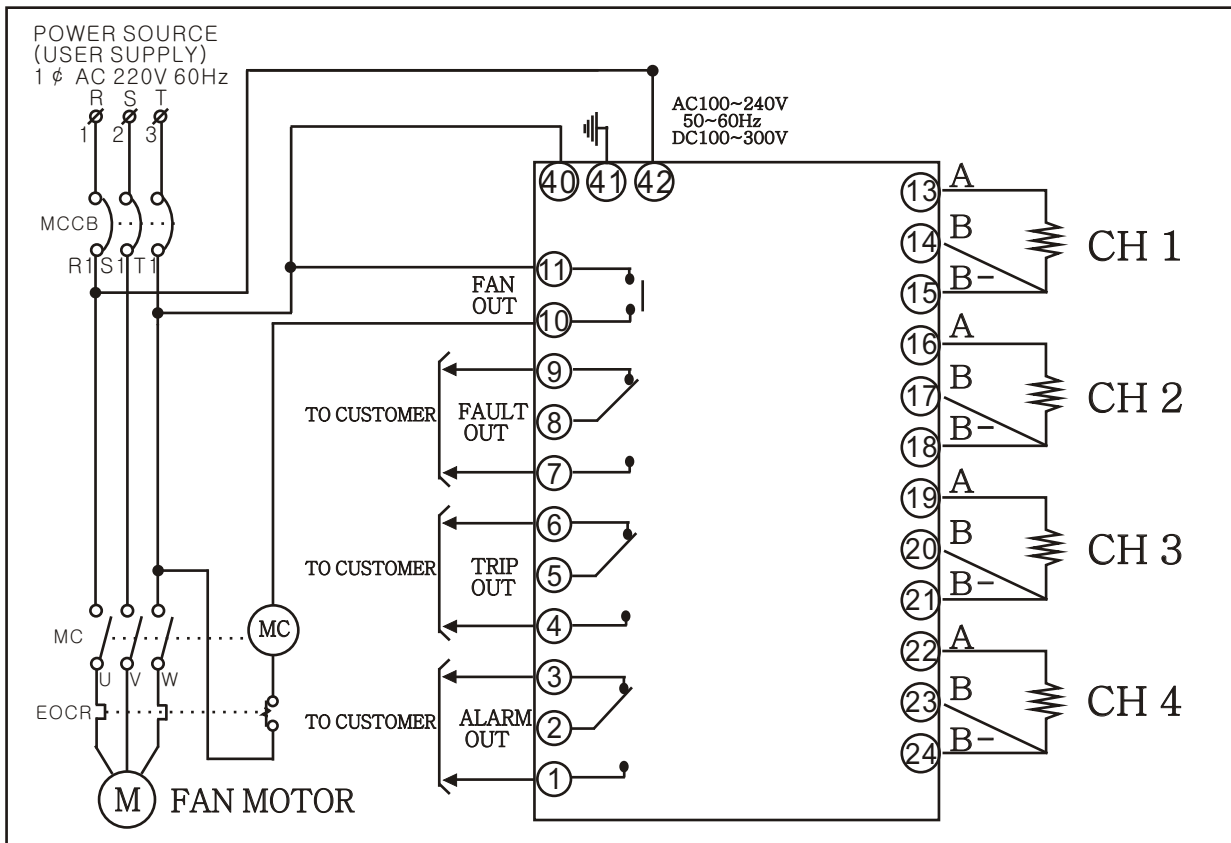



경기도 수원시 권선구 평동 23-28 A303

TEL : 031)227-4504 / FAX : 031)298-1962

A 303 ,23-28 Pyeong-Dong, Gwonseong-Gu, Suwon-City
Gyeonggi-Do, Korea, 441-230

TEL : + 82-31-227-4504 / FAX : + 82-31-298-1962

www.neurontech.kr