

# KN 805-P DIGITAL TEMPERATURE CONTROLLER

- Free voltage  
(AC100~240V(±10%) 50/60Hz, DC 100~300V)
- 4 sensor input(Pt100Ω)
- Operation setting function for each channel(run/stop)  
caution:"stop" selected channel is not displayed
- Program type function  
(Setting value)
- Temp, max storage function for each channel
- Data storage function
- Fan auto / manual function
- Buzzer function (fault, alarm, trip)
- Test function for each input channel
- Channels scanning  
SCAN : ch1-2-3-4 scanning( 2 sec)  
AUTO :automatic hottest scanning  
MAN :manual scanning
- Scan time setting function(2~10 sec)
- Outputs delay time setting function  
Fan ( 0.1~6.0 sec)  
Alarm, Trip ( 0.5~10.0 sec)



## SPECIFICATION

- |  |   |
|--|---|
| <ul style="list-style-type: none"> <li>◆ INPUT<br/>4 INPUT Pt100Ω-3Wires (DIN IEC 751)</li> <li>◆ 4 INPUT<br/>EMI FILTER, OVERVOLTAGE PROTECTION</li> <li>◆ INPUT MEASURING CYCLE<br/>60m /120m / 240m /480m SEC(setting function)</li> <li>◆ ACCURACY<br/>+/- 0.5℃ (Full Scale)</li> <li>◆ TEMPERATURE MEASURING RANGE<br/>-50~250℃</li> <li>◆ TEMPERATURE INDICATION<br/>1℃</li> <li>◆ AMBIENT TEMPERATURE<br/>OPERATION -20 to 60℃</li> <li>◆ AMBIENT HUMIDITY<br/>OPERATION 10 to 90% RH</li> <li>◆ OUTPUT CONTACTS CAPACITY<br/>TRIP,ALARM,FAULT,FAN AC 250V 10A (Resistance Load)<br/>CONTACT DC 30V 10A (Resistance Load)<br/>FAN RELAY SURGE PROTECTION</li> </ul> | <ul style="list-style-type: none"> <li>◆ ANALOG OUTPUT<br/>DC 4~20mA (RANGE:0~200℃)<br/>Load Resistance Max 500Ω<br/>(INPUT/OUTPUT ISOLATION)</li> <li>◆ SERIAL COMMUNICATION<br/>RS-485 MODBUS RTU (OPTION: RS-232)<br/>(INPUT/OUTPUT ISOLATION)</li> <li>◆ TEMPERATURE INDICATION<br/>1℃</li> <li>◆ DATA STORAGE<br/>10YEARS</li> <li>◆ POWER SUPPLY<br/>AC100 to 240V(±10%) 50/60Hz,DC100~300V(±10%)</li> <li>◆ DIELECTRIC STRENGTH<br/>AC2000V for 1min</li> <li>◆ POWER CONSUMPTION<br/>10VA</li> <li>◆ INSULATION RESISTANCE<br/>500V DC 100M ohm Minimum</li> <li>◆ WEIGHT<br/>750g</li> </ul> |
|--|---|

## TERMINAL CONNECTION

## EXTERNAL DIMENSION

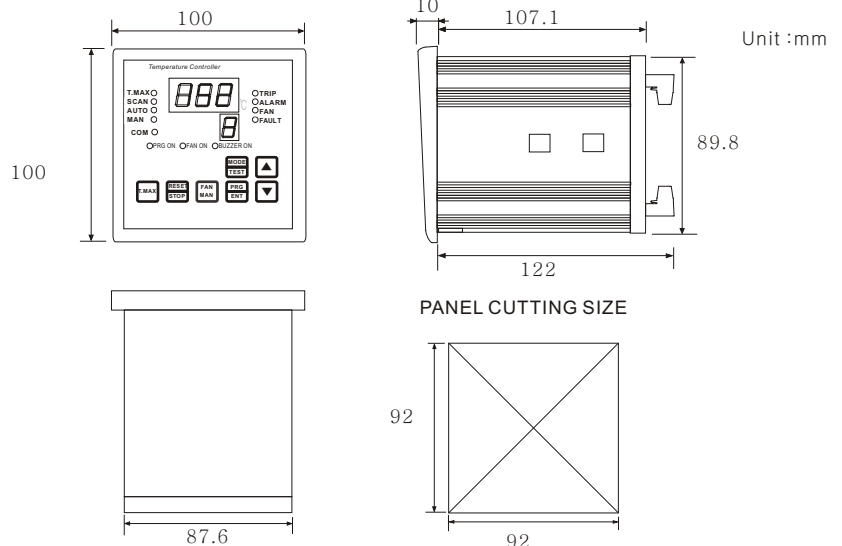
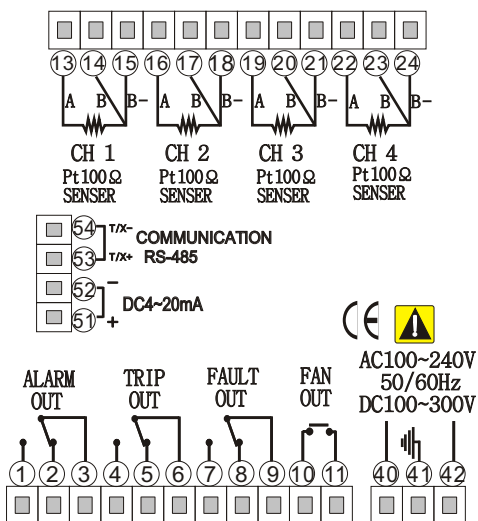

※주의※ 제품의 성능향상을 위하여 제품내용 및 사양은 통보없이 변경될 수 있습니다.

※Caution※ Product contents and specifications are subject to change without notice to improve product performance.